

# Tapping

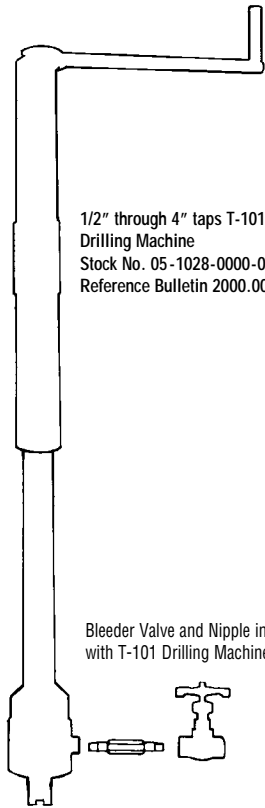

1/2" through 4" taps T-101  
Drilling Machine  
Stock No. 05-1028-0000-00  
Reference Bulletin 2000.001

Bleeder Valve and Nipple included  
with T-101 Drilling Machine



2" Valve Adapter  
00-0706-0015

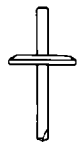

Holder Pilot  
05-0275-0000



1-1/2" Hole Saw  
(nominal)  
00-1151-0009

# Plugging

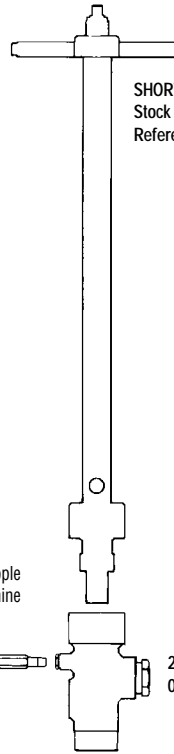

SHORTSTOPP® Plugging / Completion Machine  
Stock No. 07-1034-0000  
Reference Bulletin 2020.002

Bleeder Valve and Nipple  
included with machine

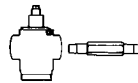

2" Housing  
08-1746-0000

1-1/2" Plugging Head  
08-1741-0000

Sealing Cup  
08-0114-0015

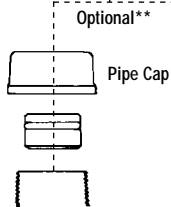
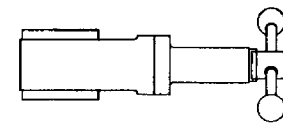

Pipe Cap

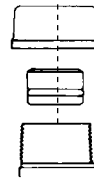

Completion Plug with O-ring\*\*\*

1-1/2" 3-WAY™ Tee

1-1/2" 3-WAY™ Tee (includes  
completion plug, O-ring, and pipe cap)  
Stock No. 26-0216-0000

1-1/2" Welding Fitting (includes

Fittings

Tapping and **SHORTSTOPP®** Plugging Machine



■ 3-WAY™ Tee  
See Bulletin 2100.002

■ Note: Consult your TDW representative for additional fitting options.

Completion



SHORTSTOPP® Plugging/  
Completion Machine  
Stock No. 07-1034-0000  
Reference Bulletin 2020.002



2" Housing  
08-1746-0000

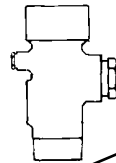

Completion Plug Holder  
07-0974-0000

# SS275-2

®

Data Sheet No. SS275-2  
Date: January 2003  
Supersedes: March 1999

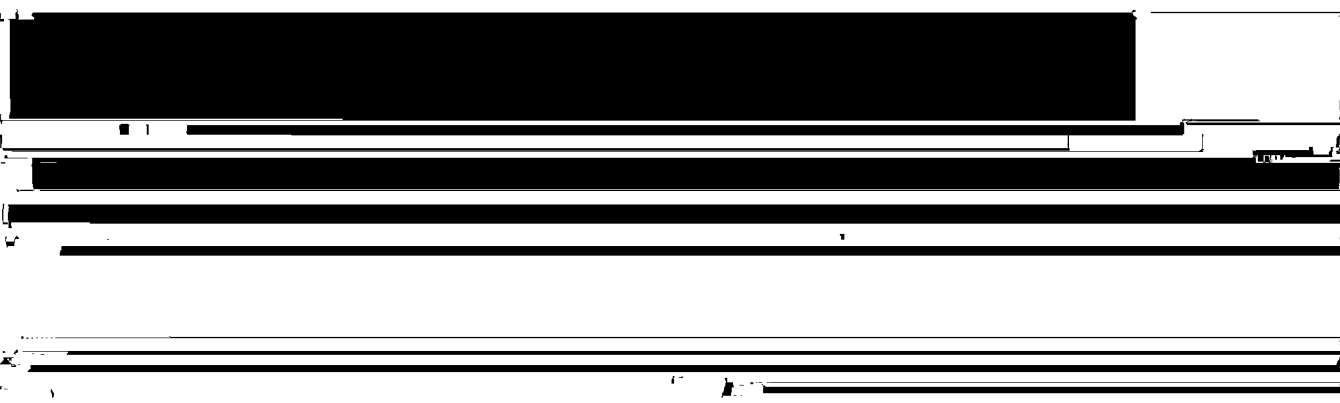
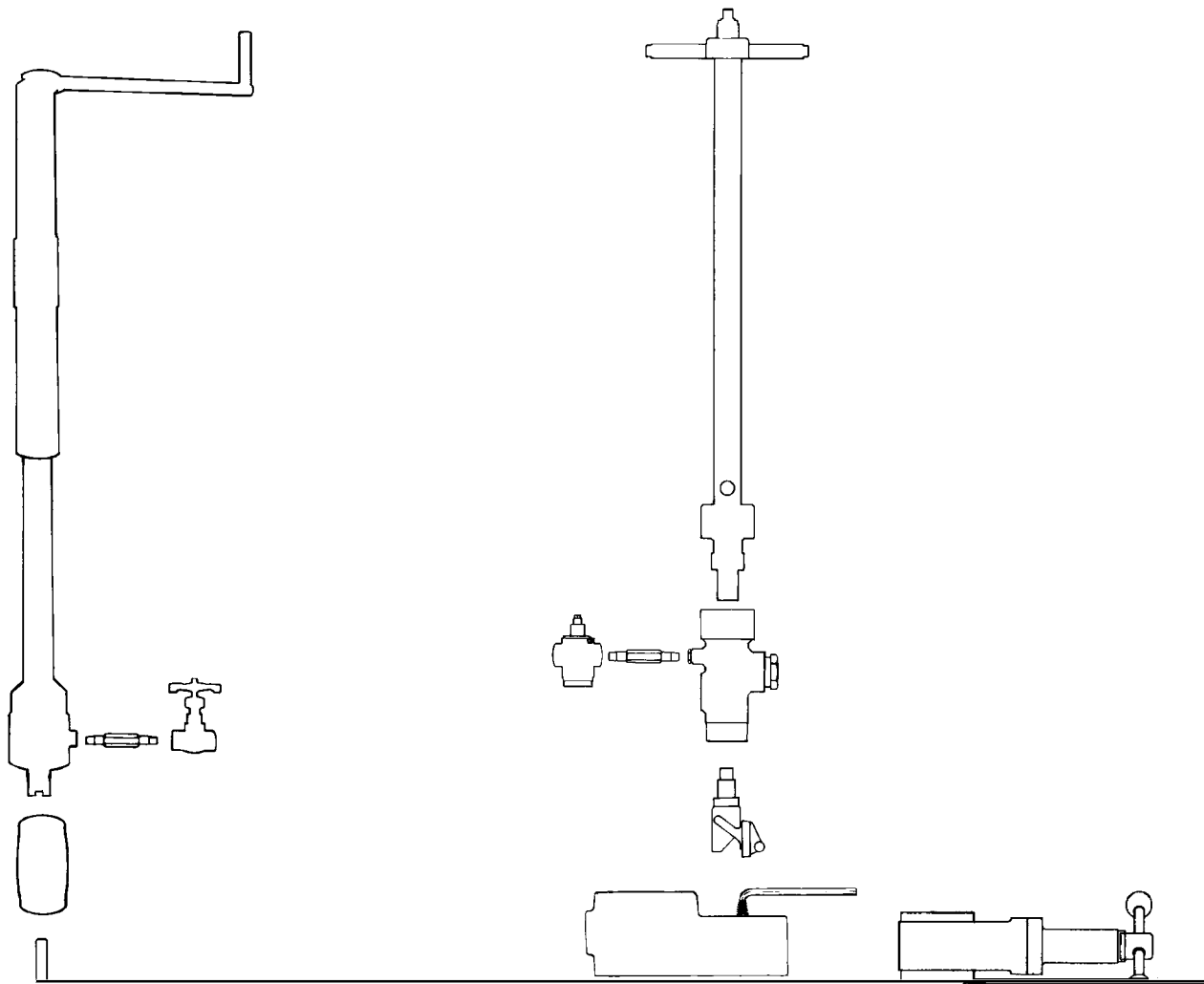



T.D. Williamson, Inc.

Data Sheet No. SS275-2

# Fittings

## Tapping and SHORTSTOPP® Plugging Machine

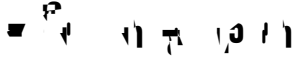

■ Welding Fitting  
See Bulletin 2100.003



■ Spherical 3-WAY™ Tee  
See Bulletin 2100.007



■ 3-WAY™ Tee  
See Bulletin 2100.002



■ Mechanical SHORTSLEEVE™ Fitting  
See Bulletin 2110.002

■ Note: Consult your TDW representative for additional fitting options.

## Completion

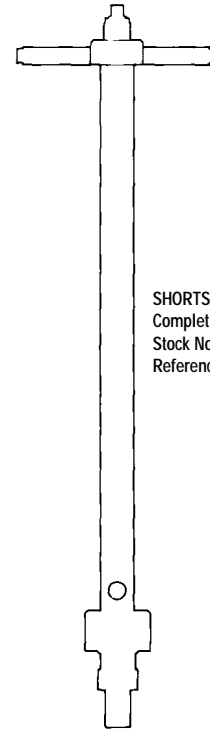

SHORTSTOPP® Plugging/  
Completion Machine  
Stock No. 07-1034-0000  
Reference Bulletin 2020.002

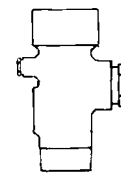

2" Housing  
08-1746-0000



Completion Plug Holder  
07-0974-0000

Data Sheet No. SS275-2

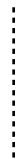



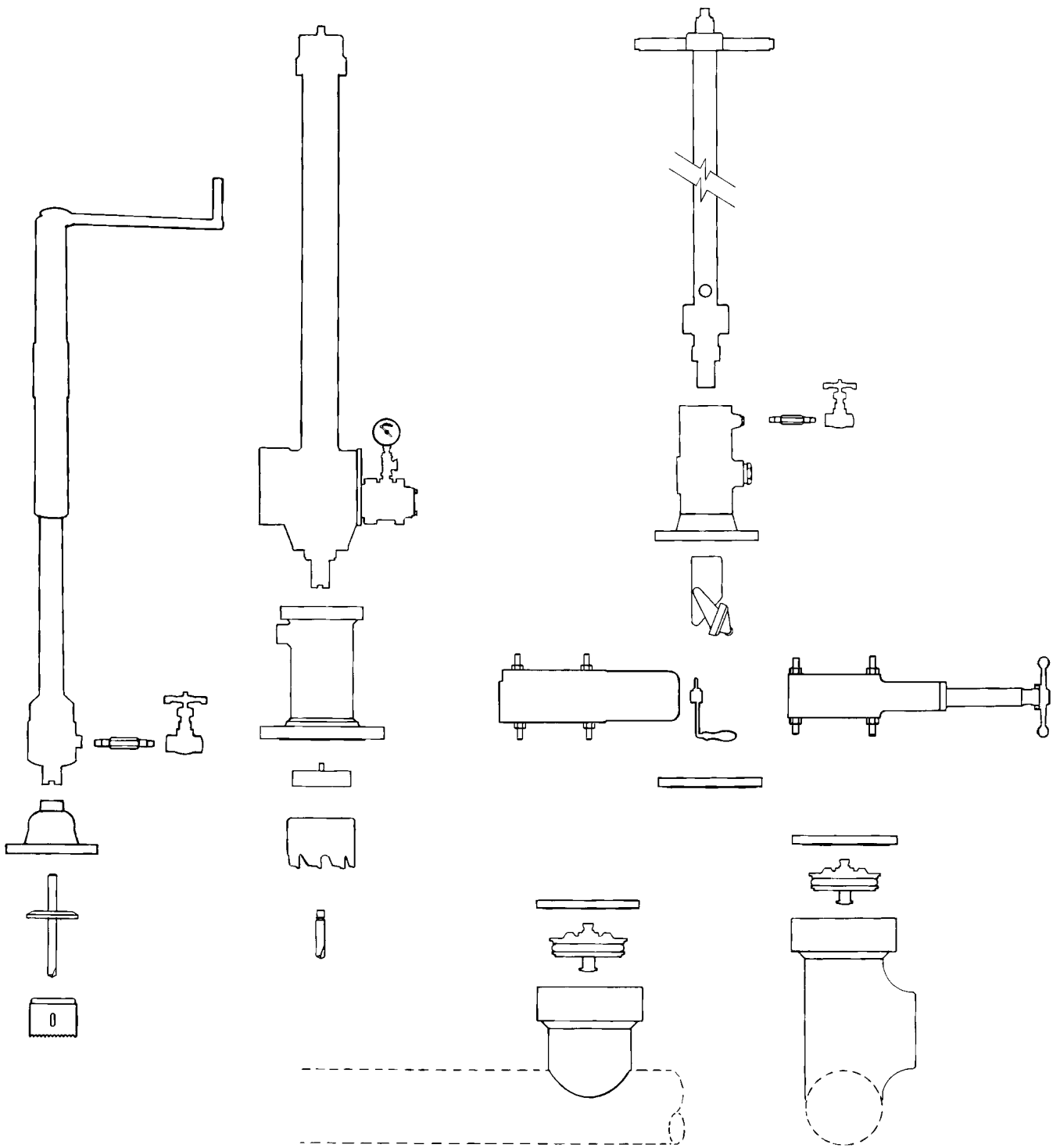

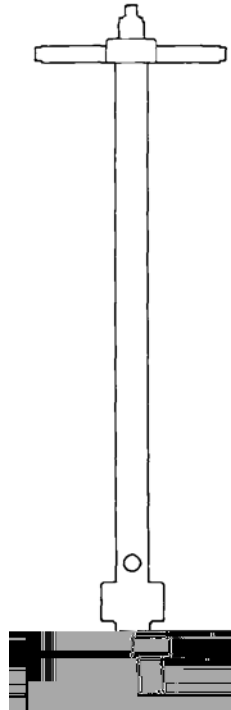



## Tapping

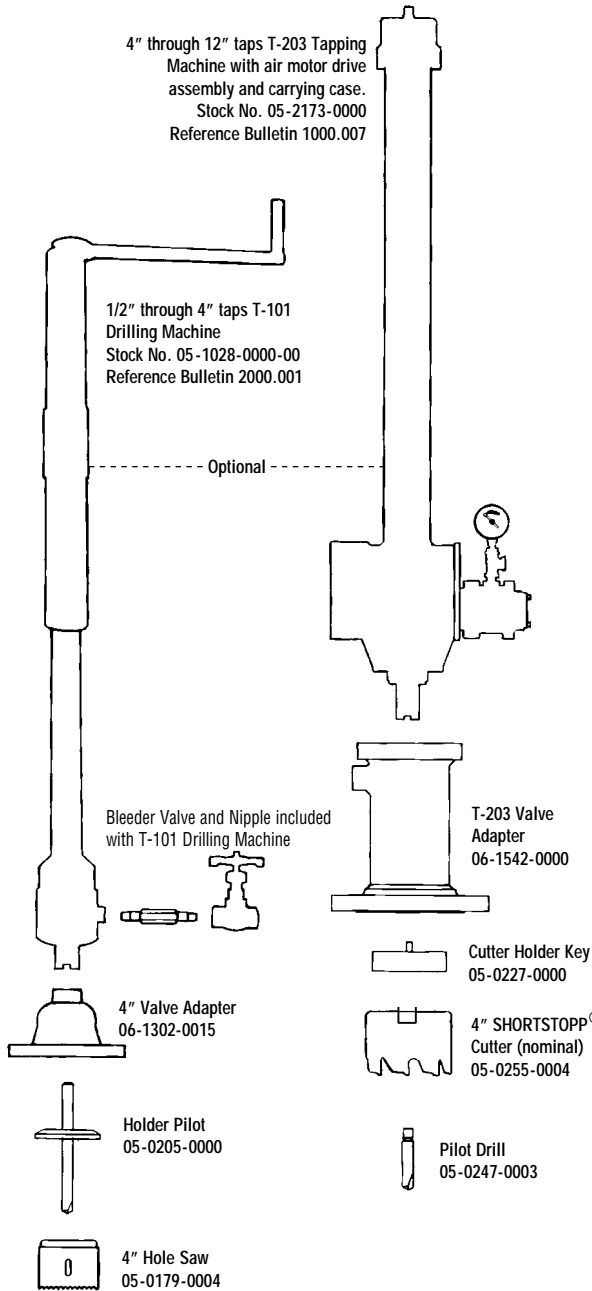

## Plugging

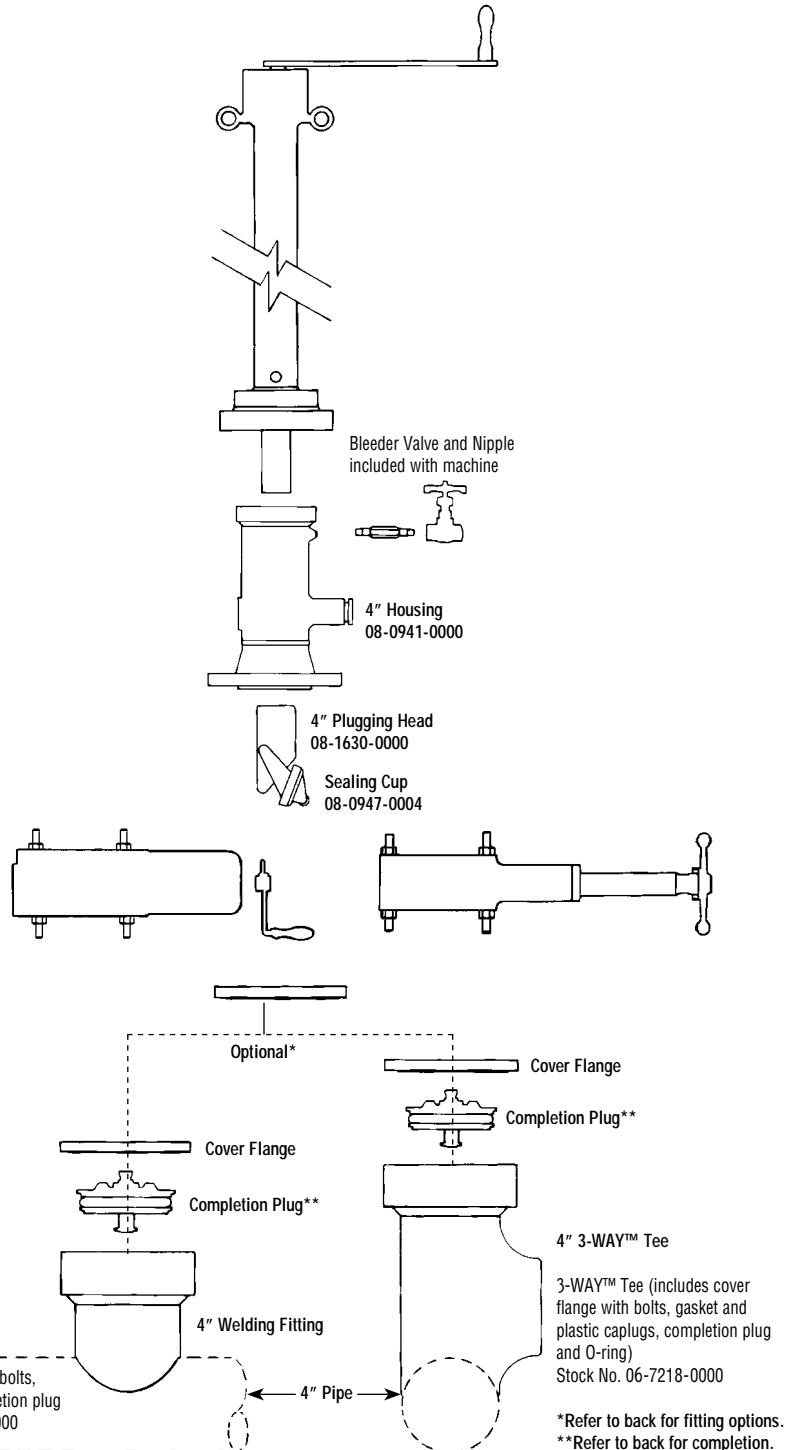



# Tapping and SHORTSTOPP<sup>®</sup> Plugging Machine



DataSheetNo. SS275-6 SS516.02<S275-6

Equipment Needed to Plug a 6" Gas Main to 285 psi

## Tapping

■ Note: Either the T-101 XL or T-203 Tapping Machine is recommended for 6" taps.

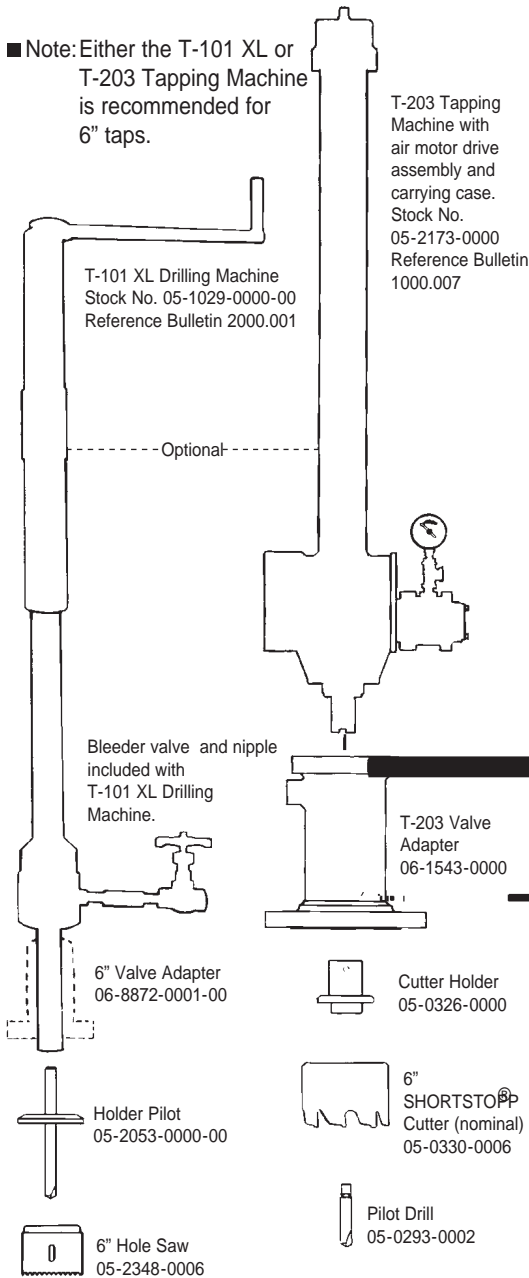

## Plugging

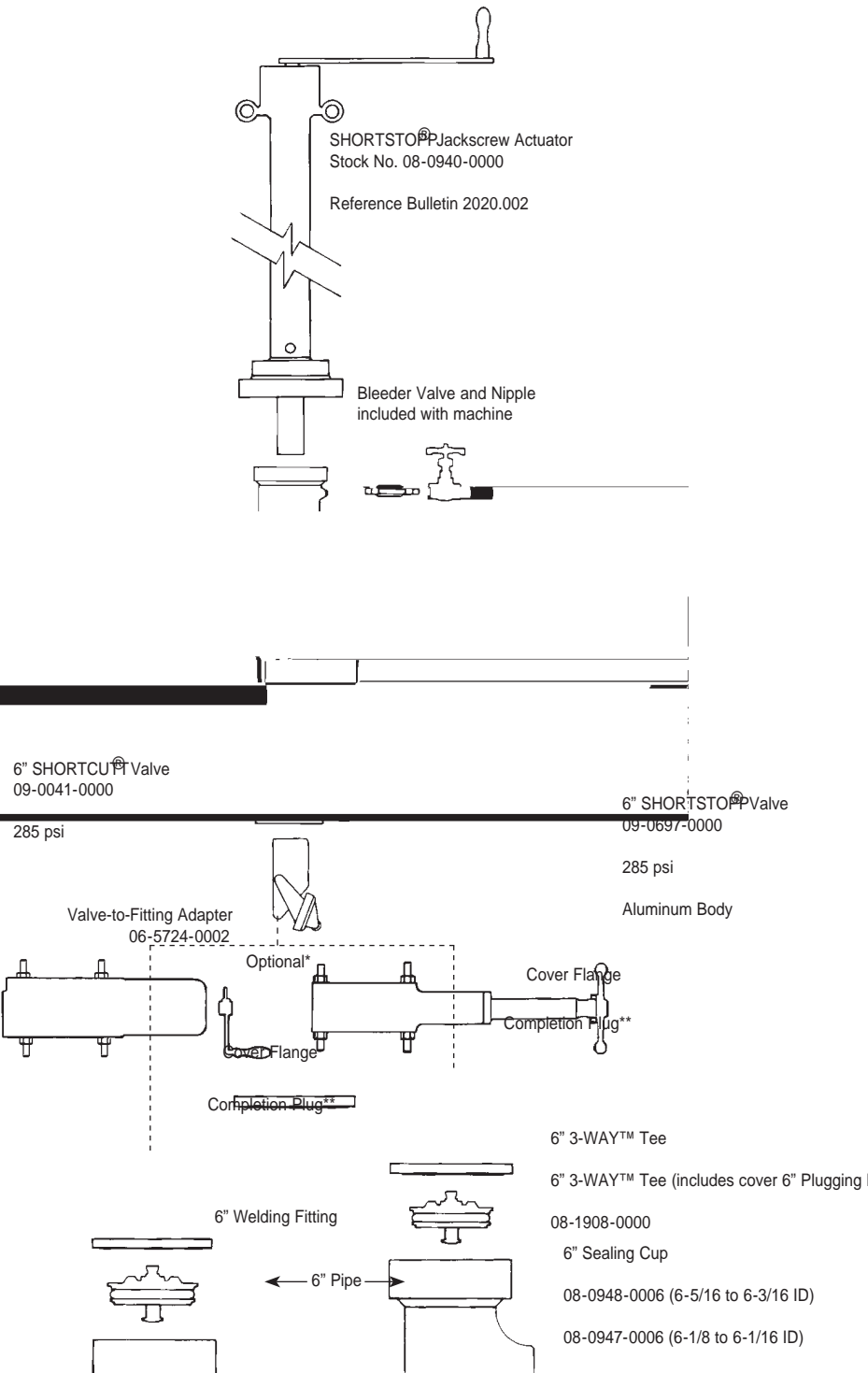



# Tapping and SHORTSTOPP® Plugging Machine

6" Gas Main to 285 psi

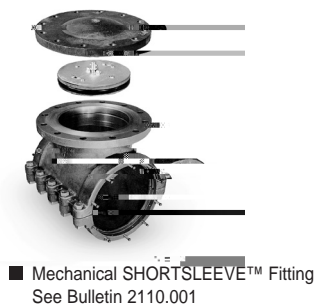
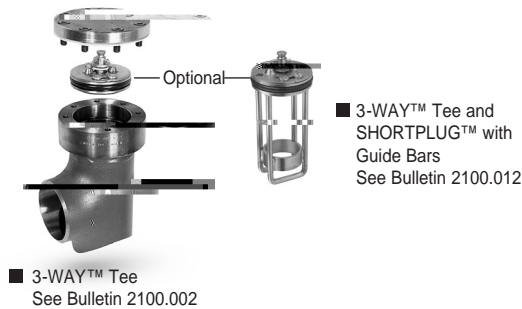
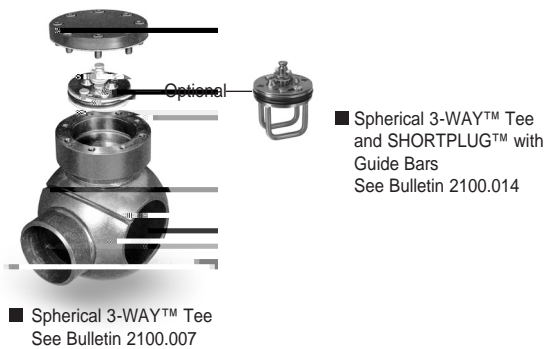
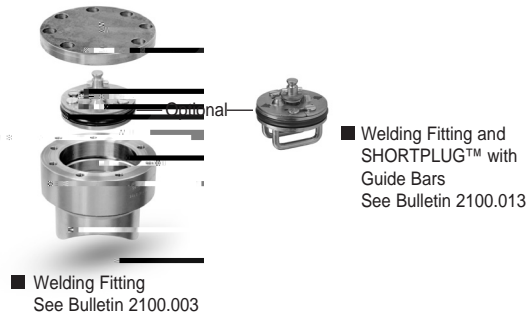

■ Note: Consult your TDW representative for additional fitting options.

## Completion

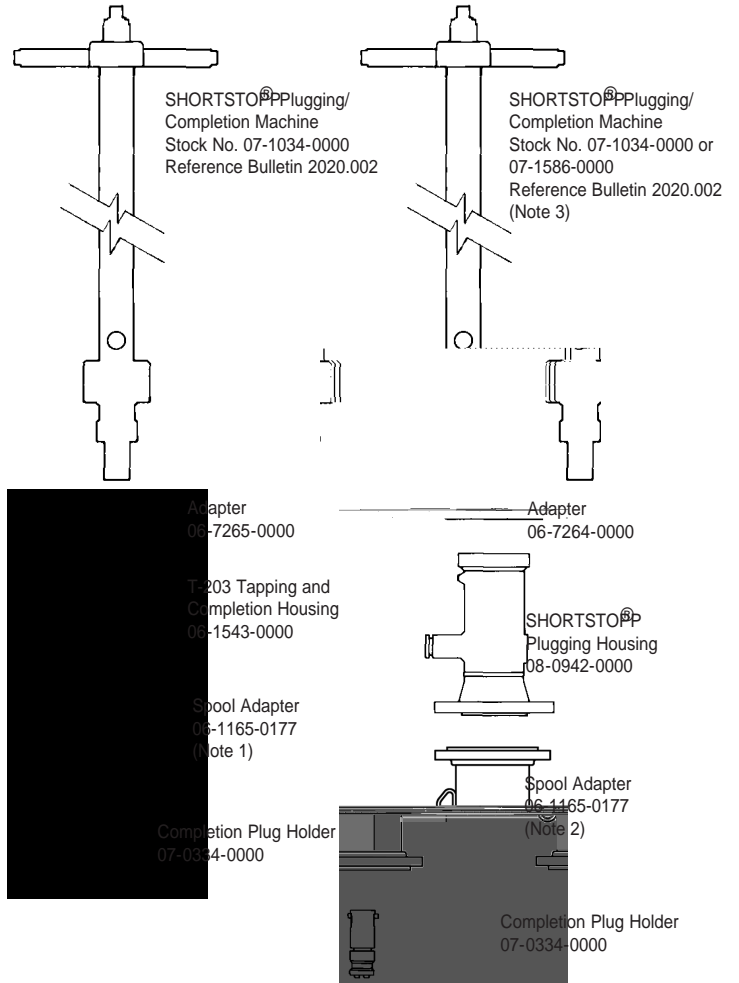

- Note 1: 6-inch Spool Adapter required to set 6-inch SHORTPLUG™ with Guide Bars in SHORTSTOPP Type II 3-Way™ Tee and Spherical fittings using the 06-1543-0000 Adapter.
- Note 2: 6-inch Spool Adapter required to set 6-inch SHORTPLUG™ with Guide Bars in SHORTSTOPP Type II 3-Way™ Tee fittings using the 08-0942-0000 Housing. Also must use the 07-1586-0000 Completion Machine with 48-inch travel.
- Note 3: The 07-1586-0000 Completion Machine with 48" travel is required to set 6" SHORTPLUG™ with Guide Bars in SHORTSTOPP Type II fittings using the 08-0942-0000 Adapter.

# Tapping

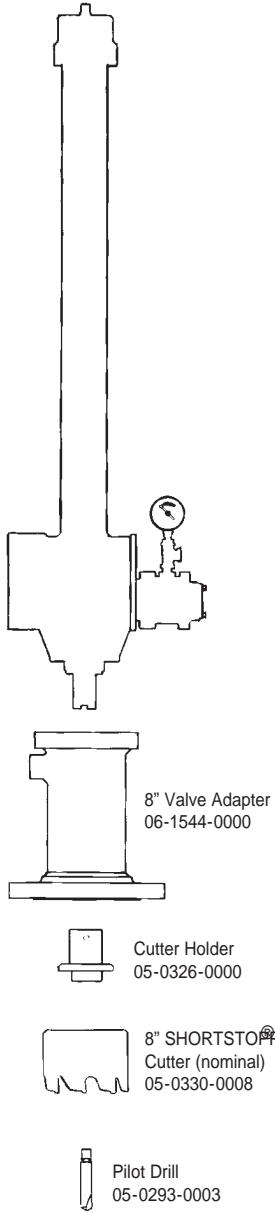

# Plugging

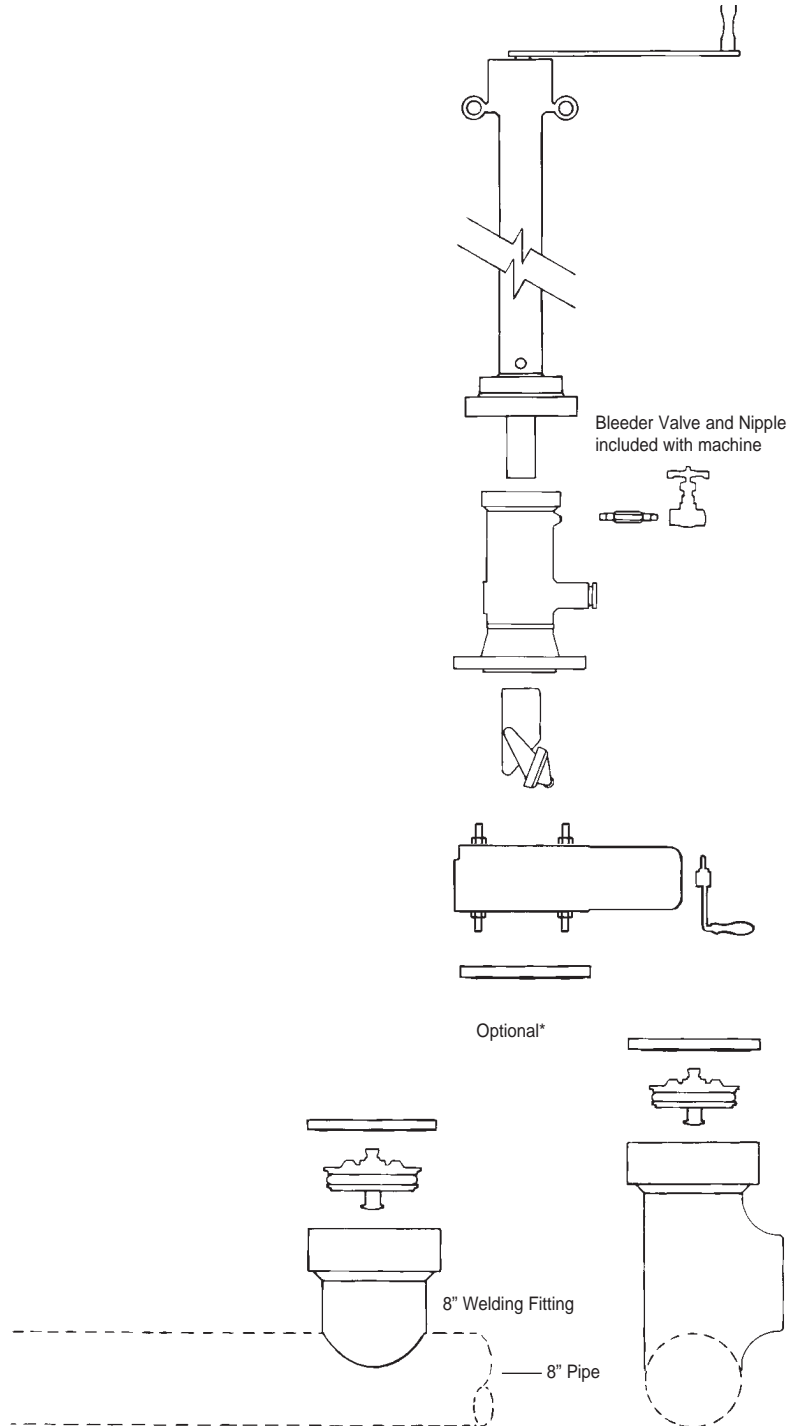



# Tapping and SHORTSTOPP® Plugging Machine

## 8" Gas Main to 285 psi

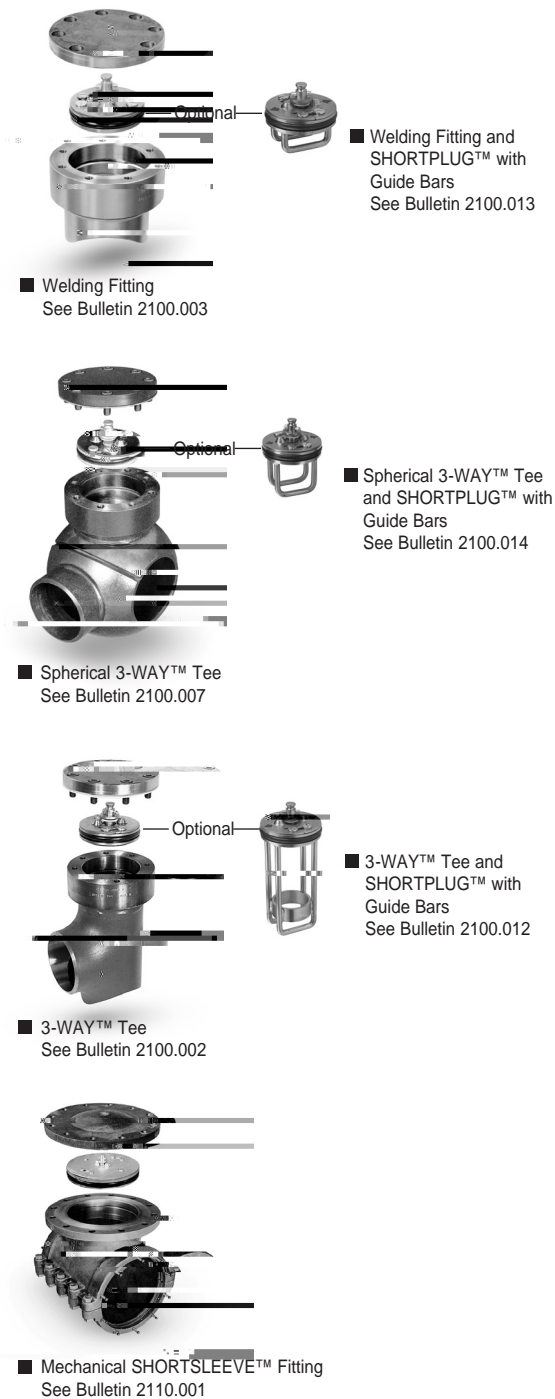

## Completion

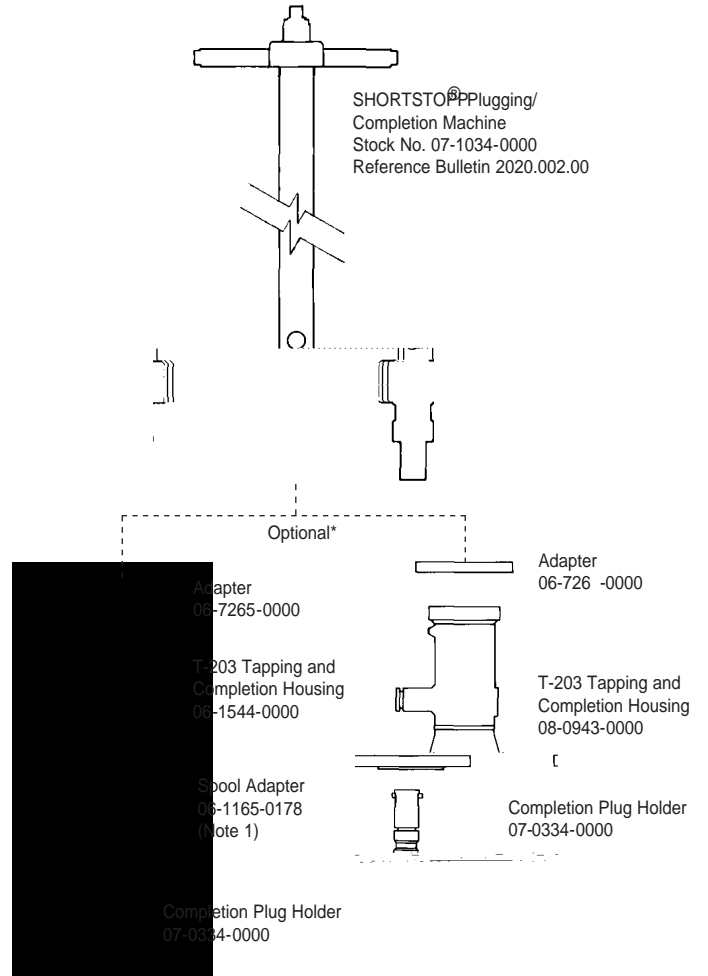

■ Note 1: 8-inch Spool Adapter required to set 8-inch SHORTPLUG™ with Guide Bars in SHORTSTOPP Type II 3-Way™ Tee fittings using the 06-1544-0000 Adapter.

■ Note: Consult your TDW representative for additional fitting options.

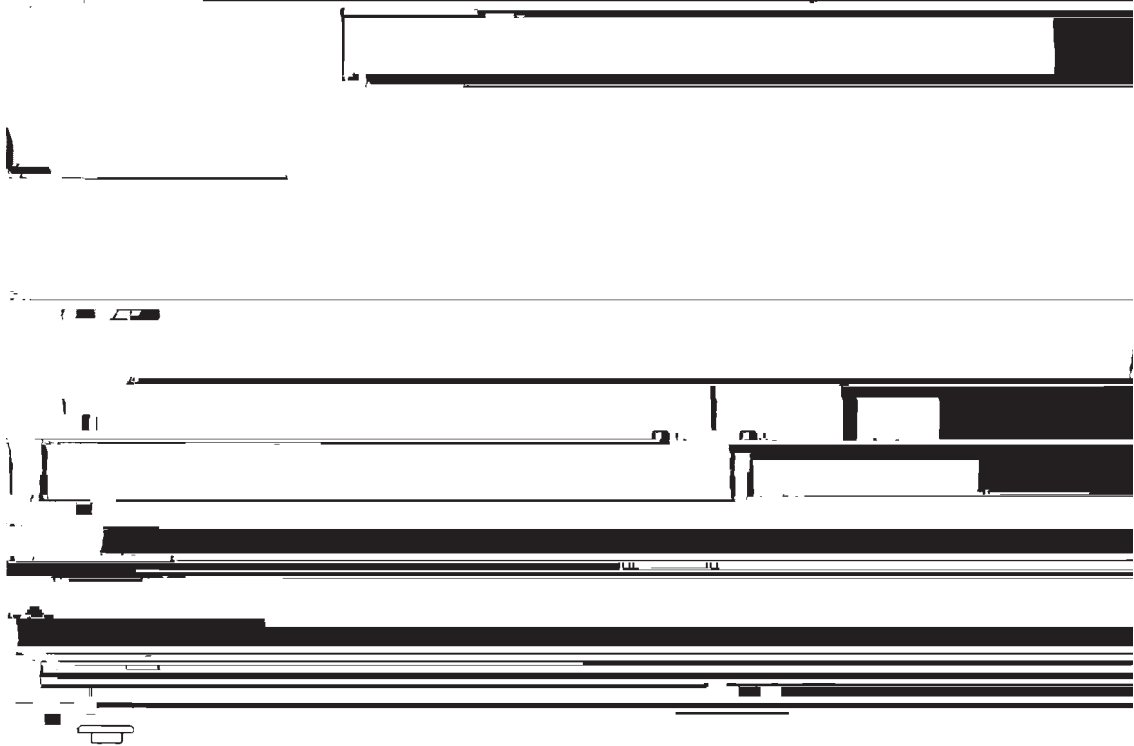
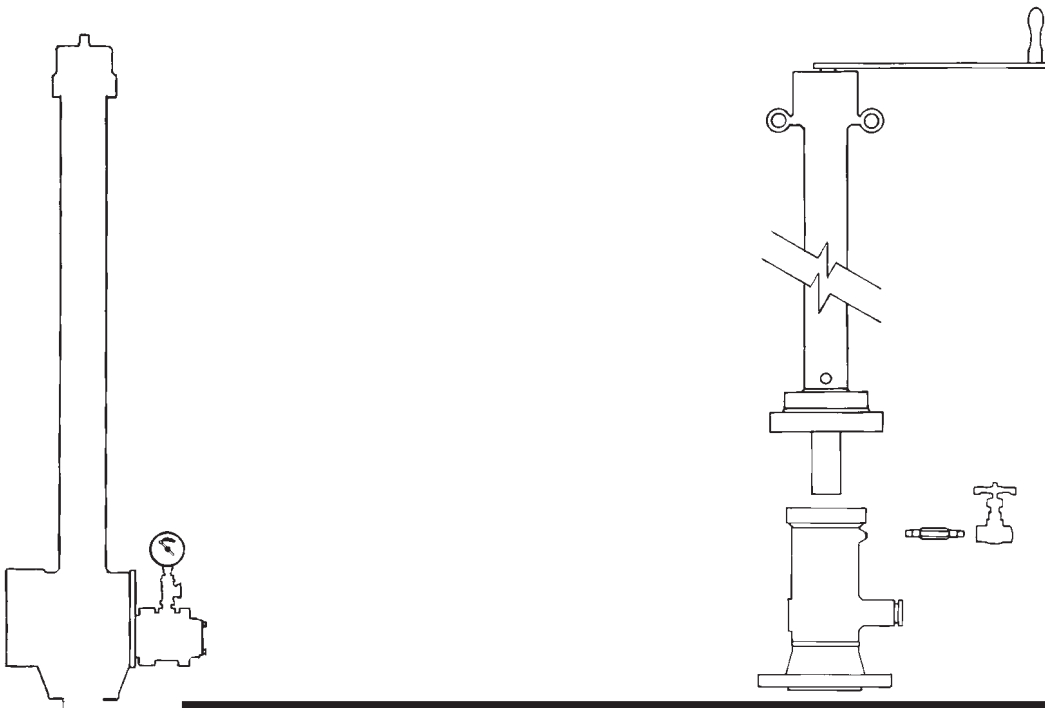

Tapping and SHORTSTOPP®



# Tapping and SHORTSTOPP<sup>®</sup> Plugging Machine

Equipment Needed to Plug a 12" Gas Main to 285 psi

Data Sheet No. SS275-12

Date:

Supersedes:

## Tapping

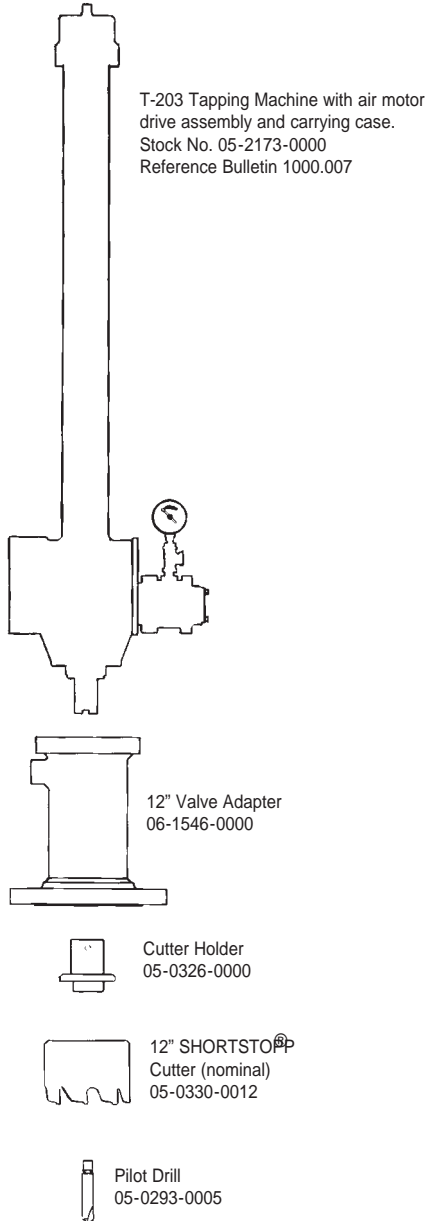

## Plugging

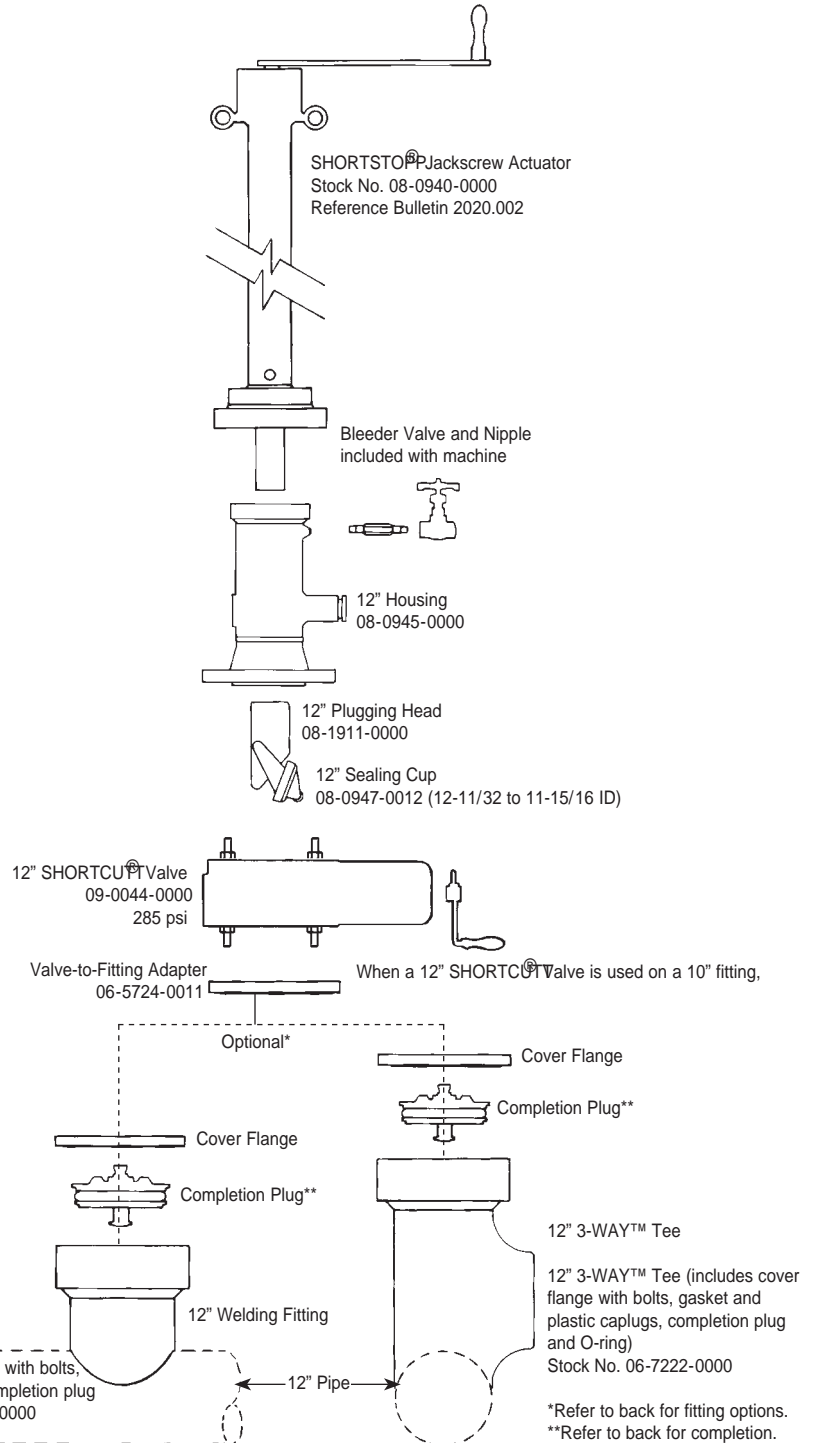



# Tapping and SHORTSTOPP® Plugging Machine

12" Gas Main to 285 psi

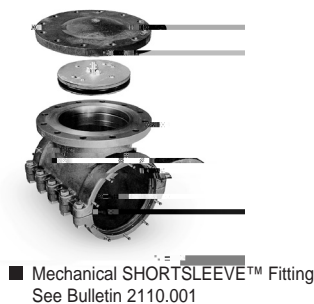
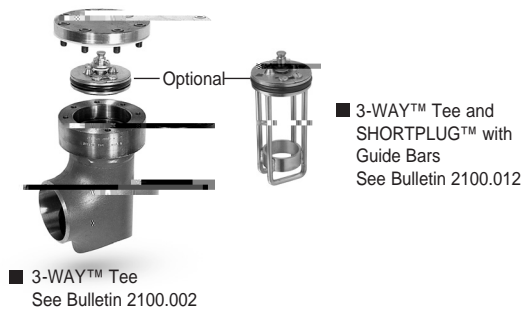
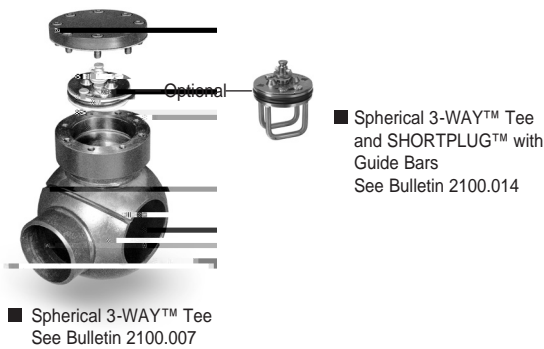
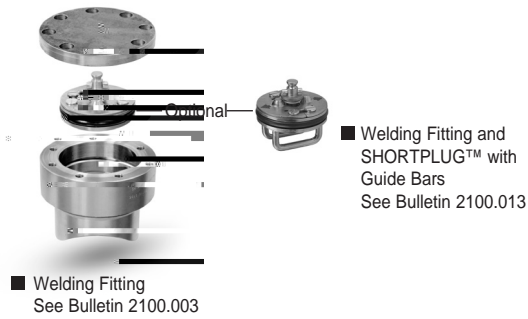

■ Note: Consult your TDW representative for additional fitting options.

## Completion

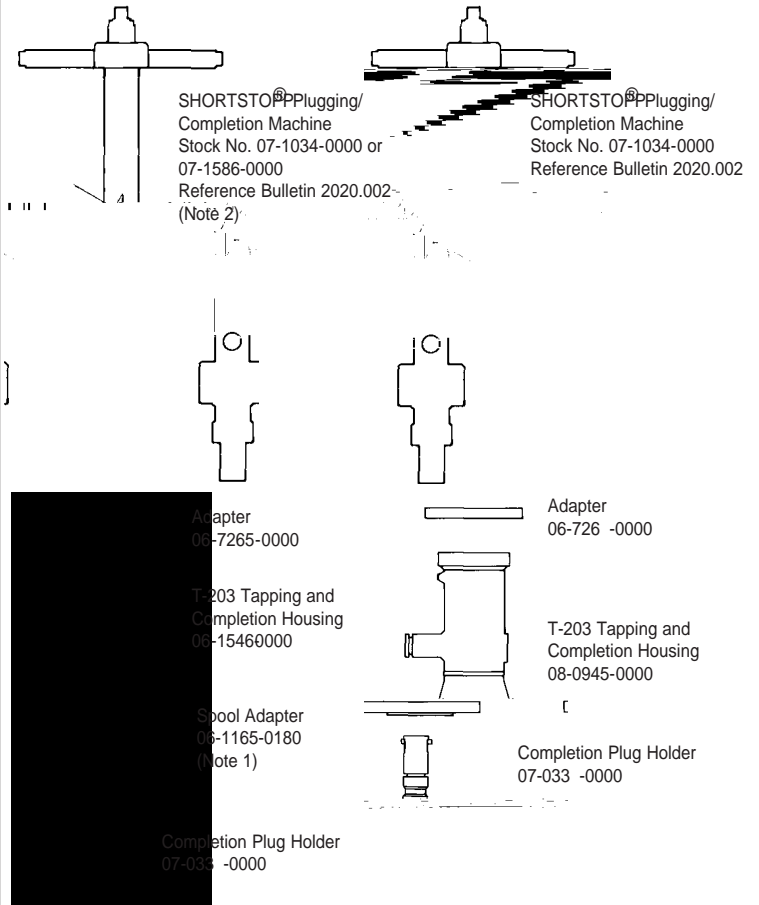

■ Note 1: 12-inch Spool Adapter required to set 12-inch SHORTPLUG™ with Guide Bars in SHORTSTOPP Type II 3-Way™ Tee fittings using the 06-1546-0000 Adapter and 07-1586-0000 Completion Machine

Note 2: The 07-1586-0000 Completion Machine with 48" travel is required to set 12" SHORTPLUG™ with Guide Bars in SHORTSTOPP Type II 3-Way™ Tee fittings using the 06-1546-0000 Adapter.